

# Sikh Robotics – Motor Encoder

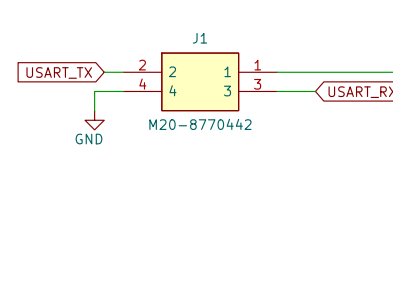

System Connector



Protection Components

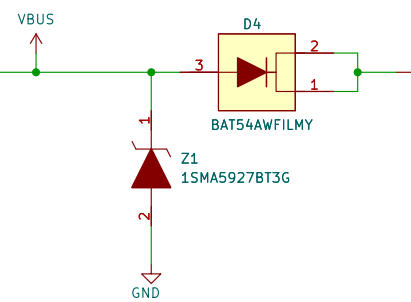

5V to 3V3 Regulator

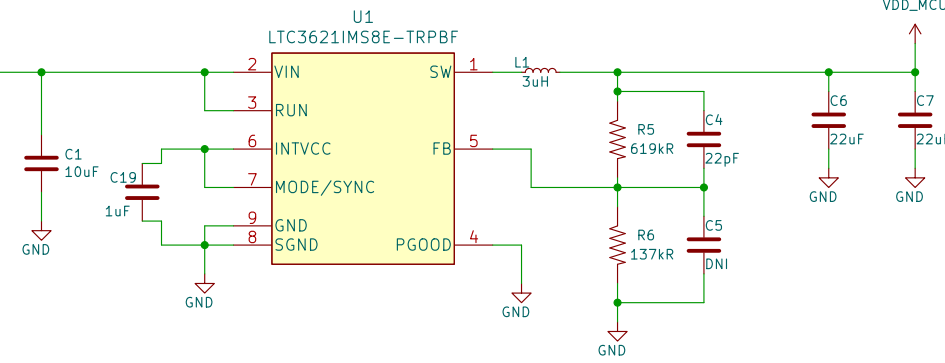

Power Capacitors

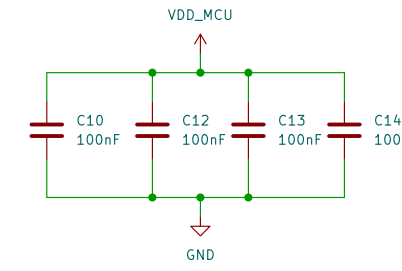

Boot Options

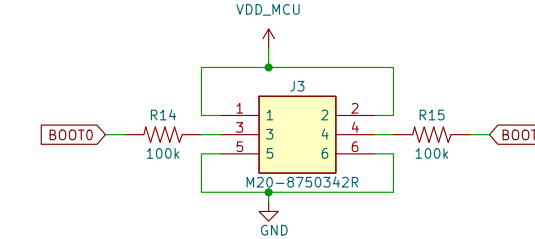

TX/RX Swap

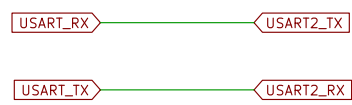

MCU – STM32F103C8T6

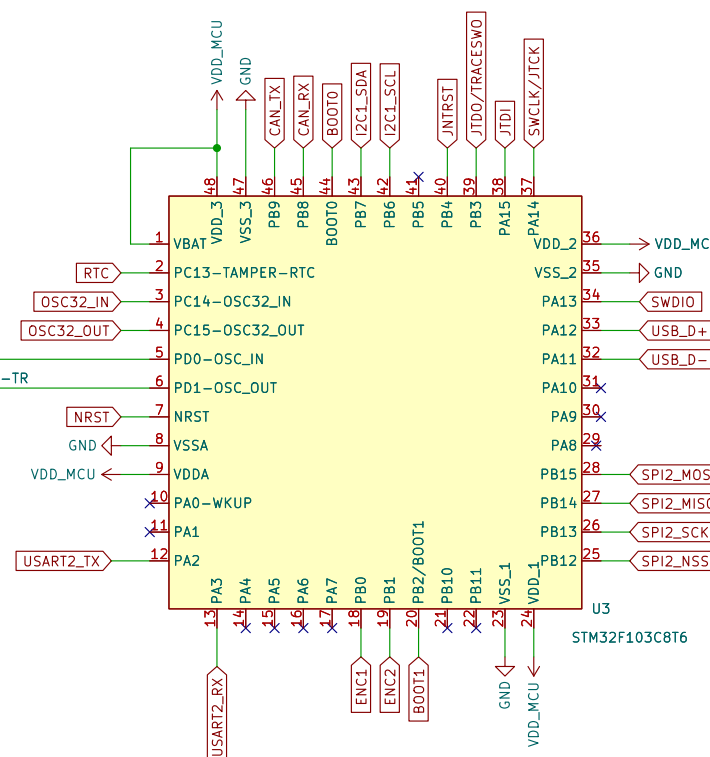

32.768KHZ Crystal

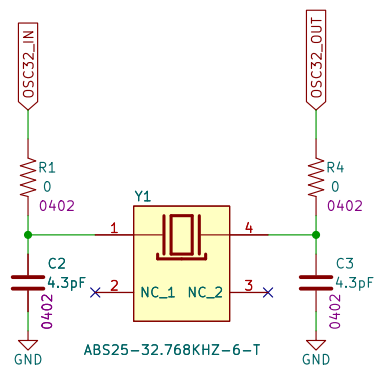

8MHz Crystal

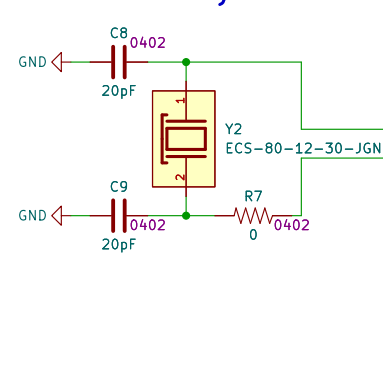

SW Programming

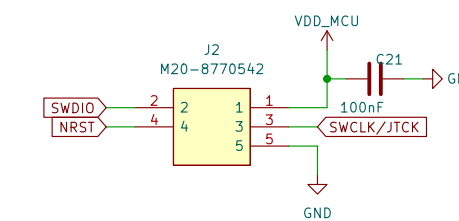

micro USB (Optional)

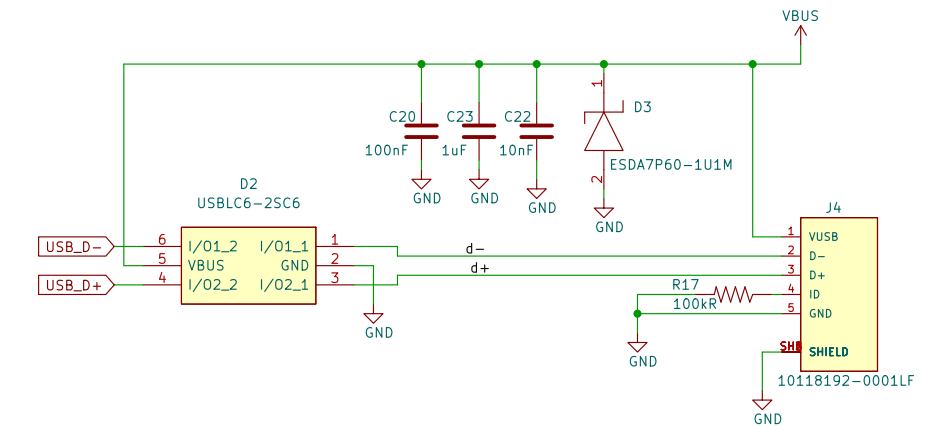

MCU Reset Button

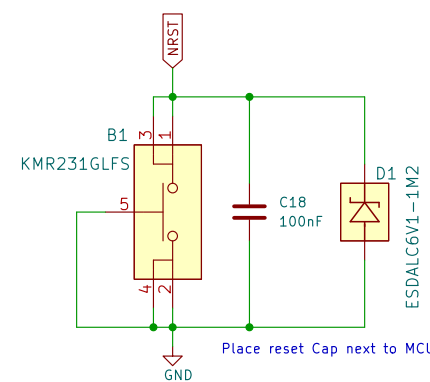

Magnetic Encoder 1

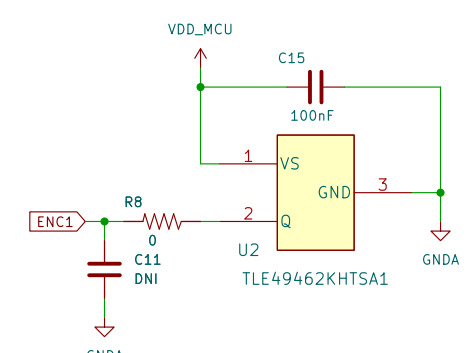

Magnetic Encoder 2

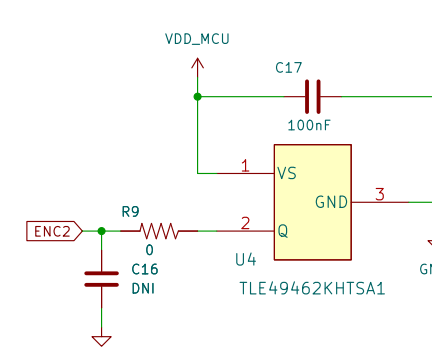

Misc Connections

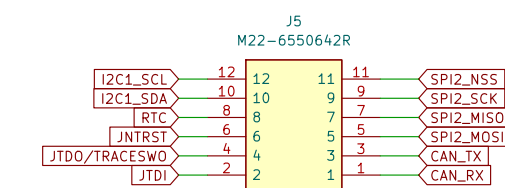

Mounting Holes

